

# SPRINKLER

## Self-priming centrifugal pumps

 Clean water

 Domestic use

 Civil use



### PERFORMANCE RANGE

- Flow rate up to **300 l/min** (18.0 m<sup>3</sup>/h)
- Head up to **25.5 m**

### APPLICATION LIMITS

- Manometric suction lift up to **9 m** (HS)
- Liquid temperature between **-10 °C** and **+40 °C**
- Ambient temperature up to **+40 °C**
- Max. working pressure **10 bar**
- Continuous service **S1**

### CONSTRUCTION AND SAFETY STANDARDS

EN 60335-1  
IEC 60335-1  
CEI 61-150

EN 60034-1  
IEC 60034-1  
CEI 2-3



### CERTIFICATIONS

Company with management system certified DNV  
ISO 9001: QUALITY



### INSTALLATION AND USE

Suitable for use with clean water and with liquids that are not chemically aggressive towards the materials from which the pump is made. The self-priming **SPRINKLER** pumps are designed to pump water even in cases where air is present. Because of their reliability and the fact that they are easy to use, they are recommended for use in domestic and civil applications such as the distribution of water in combination with pressure tanks, and for the irrigation of gardens and orchards, etc.

The pump should be installed in an enclosed environment or sheltered from inclement weather.

### OPTIONS AVAILABLE ON REQUEST

- Other voltages or 60 Hz frequency
- IPX5 protection

## CHARACTERISTIC CURVES AND PERFORMANCE DATA

50 Hz n= 2900 min<sup>-1</sup> HS= 0 m

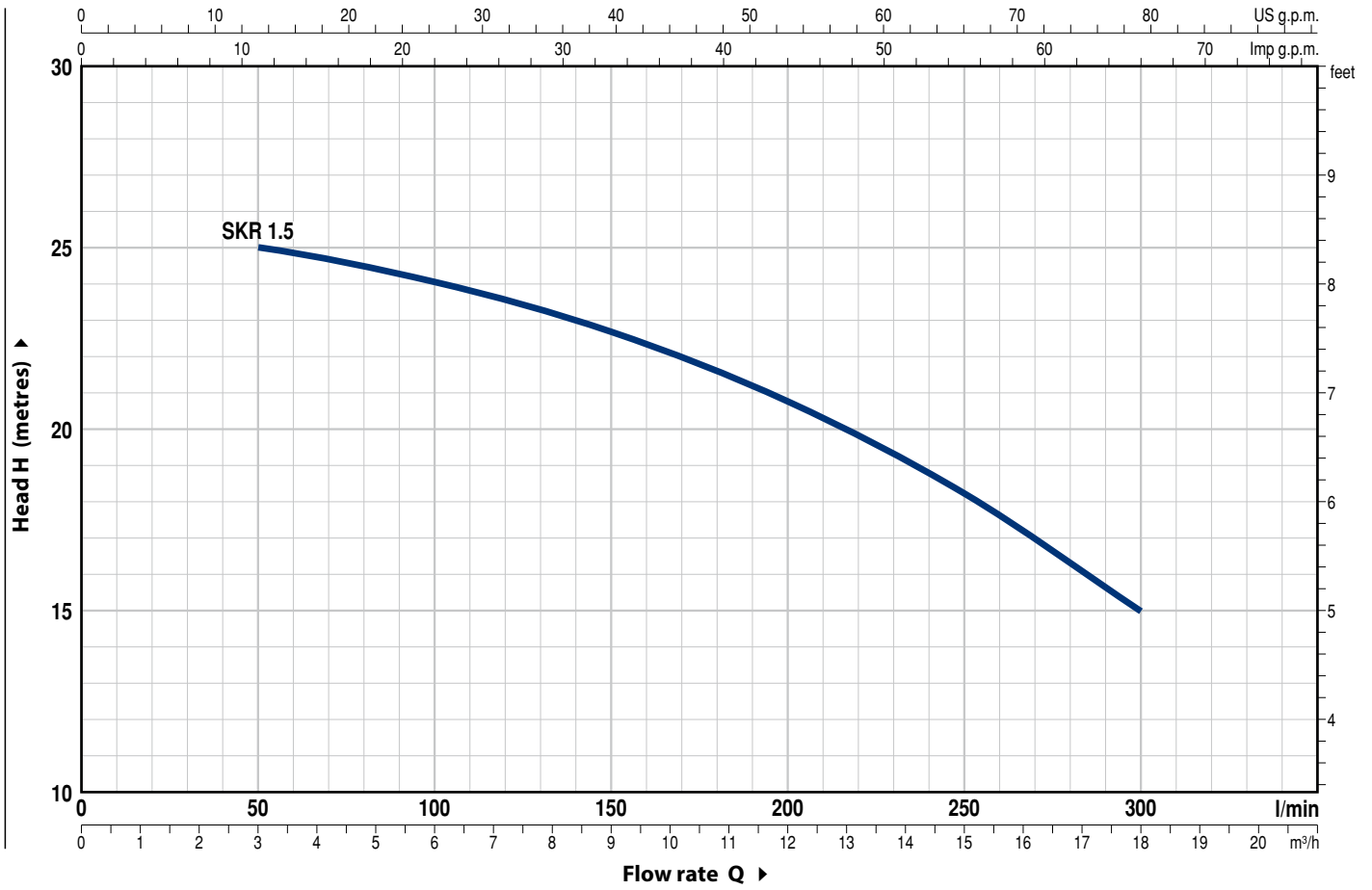

MODEL		POWER (P <sub>2</sub> )			Q	0	3.0	6.0	9.0	12.0	15.0	18.0
Single-phase	Three-phase	kW	HP	▲		0	50	100	150	200	250	300
SKRm 1.5	SKR 1.5	1.5	2	IE3	H metres	25.5	25	24	22.7	20.8	18.2	15

Q = Flow rate H = Total manometric head HS = Suction height

Tolerance of characteristic curves in compliance with EN ISO 9906 Grade 3B.

▲ Performance class of the three-phase motor (IEC 60034-30-1)

## STANDARD INSTALLATION

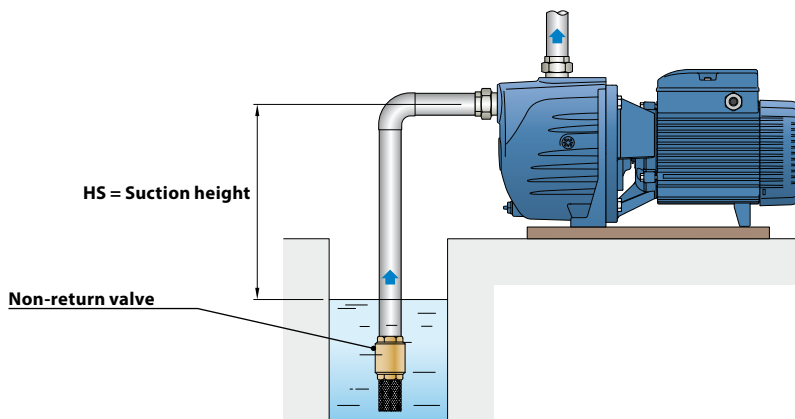

# SPRINKLER

## POS. COMPONENT

## CONSTRUCTION CHARACTERISTICS

1	<b>PUMP BODY</b>	Cast iron with an Epoxy Electro Coating treatment, with threaded ports in compliance with ISO 228/1				
2	<b>BODY BACKPLATE</b>	Cast iron with an Epoxy Electro Coating treatment				
3	<b>DIFFUSER</b>	Noryl FE1520PW				
4	<b>IMPELLER</b>	Noryl FE1520PW				
5	<b>MOTOR SHAFT</b>	Stainless steel EN 10088-3 - 1.4104				
6	<b>MECHANICAL SEAL</b>	<b>Seal Model</b>	<b>Shaft Diameter</b>	<b>Stationary ring</b>	<b>Rotational ring</b>	<b>Materials Elastomer</b>
		FN-18	Ø 18 mm	Graphite	Ceramic	NBR
7	<b>BEARINGS</b>	6204 ZZ / 6204 ZZ				
8	<b>CAPACITOR</b>	<b>Pump Single-phase</b>	<b>Capacitance (220-230 V or 240 V)</b>	<b>(110 V)</b>		
		SKRm 1.5	45 µF - 450 VL	80 µF - 250 VL		
9	<b>ELECTRIC MOTOR</b>	<p><b>SKRm:</b> single-phase 220-230 V - 50 Hz with thermal overload protector incorporated into the winding.  <b>SKR:</b> three-phase 230/400 V - 50 Hz.</p> <p>⇒ <b>The three-phase pumps are fitted with high performance motors in class IE3 (IEC 60034-30-1)</b></p> <ul style="list-style-type: none"> <li>- Insulation: class F</li> <li>- Protection: IP X4</li> </ul>				

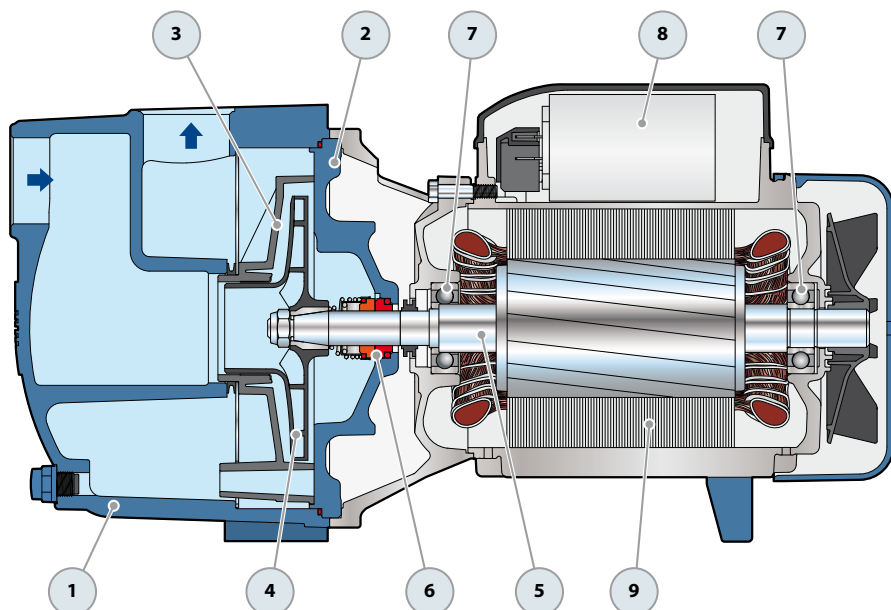

## DIMENSIONS AND WEIGHT

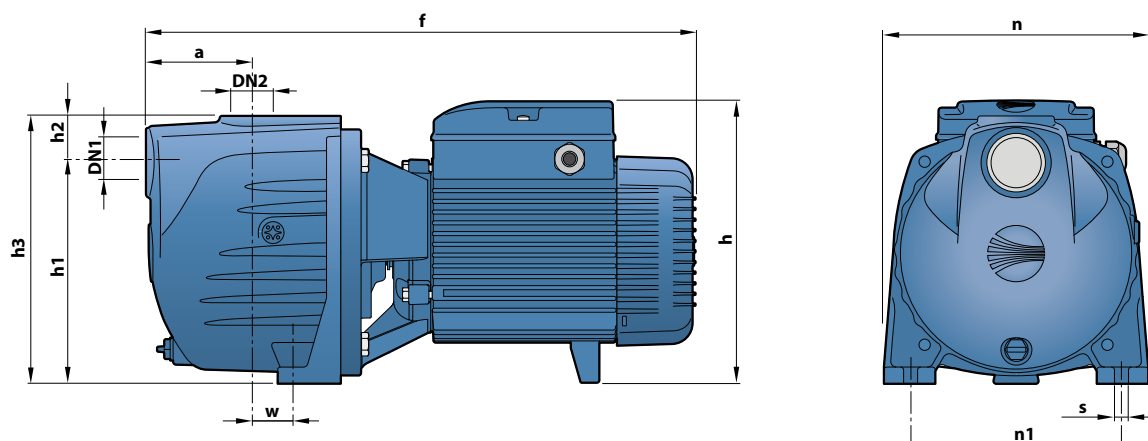

MODEL		PORTS		DIMENSIONS mm										kg	
Single-phase	Three-phase	DN1	DN2	a	f	h	h1	h2	h3	n	n1	w	s	1~	3~
SKRm 1.5	SKR 1.5	1½"	1½"	91	465	241	186	39	225	223	178	37.5	11	26.9	26.9

## ABSORPTION

MODEL	VOLTAGE	
Single-phase	220-230 V	240 V
SKRm 1.5	10.3 A	-

MODEL	VOLTAGE					
Three-phase	230 V	400 V	690 V	240 V	415 V	720 V
SKR 1.5	6.7 A	3.9 A	2.3 A	-	-	-

## PALLETIZATION

MODEL		GROUPAGE	CONTAINER
Single-phase	Three-phase	n. pumps	n. pumps
SKRm 1.5	SKR 1.5	35	49